

COM 4413 – Family Communication  
Course Materials Handbook  
(Spring 2004)

Prepared by

H. Paul LeBlanc III

for

The University of Texas at San Antonio

Department of Communication

## TABLE OF CONTENTS

|  |    |
|--|----|
| Syllabus .....                               | 1  |
| Grade Monitoring Form .....                  | 4  |
| List of Important Dates .....                | 5  |
| Schedule of Assignments and Activities ..... | 6  |
| The Family Genogram .....                    | 7  |
| Family Network Diagram .....                 | 9  |
| Oral History and Transcription .....         | 10 |
| The Weekly Journal .....                     | 11 |
| References .....                             | 12 |
| Course Feedback Form .....                   | 14 |

## SYLLABUS

---

H. Paul LeBlanc III, PhD  
Department of Communication  
HSS 4.02.14

Office: 458-7724, Fax: 458-5991  
E-mail through WebCT  
Office hours: 8:00 - 8:50 Monday or Friday

---

### **COURSE OBJECTIVES**

This course facilitates understanding of the major theories and concepts in the study of communication phenomena in family relationships. Emphasis is placed on critical analysis of communication research into the family context. An important goal of this class is to foster students' insight into their own experience of family and to enable students to apply course-related concepts to their relationships.

Lectures, discussion, classroom exercises, written assignments, and in-class and out-of-class observations will be used to aid the development of knowledge and skills relating to the study of communication.

The aim is to merge theory and practice throughout the classroom experience. To this end, we will maintain a stimulating, interactive, open, and friendly classroom environment that fosters self and other insight, critical thinking, intellectual growth and communicative competence. The following objectives are core to the course:

- To achieve a clear understanding of theories of communication in the family,
- To extend understanding and appreciation of the discipline of communication, and
- To develop critical thinking and analytical skills.

### **TEXT**

Turner, L. H., & West, R. (2002). *Perspectives on family communication* (2nd ed.). Boston: McGraw-Hill.

### **POLICIES**

**Cheating, plagiarism and collusion will not be tolerated.** All work submitted must be the original work of the student, for this course only (no submitting the same assignment in more than one class). The penalty for plagiarism, cheating or collusion may include failing the assignment, failing the course, or expulsion from the University depending on the severity of the infraction. Please see the University's Student Code of Conduct for information regarding these policies.

**All course requirements must be fulfilled in order to successfully pass the course.** Late assignments will not be accepted. Incompletes will be given only in very limited cases and only when they meet the Policy for Incompletes on file in the Department of Communication office, as well as the University requirements for Incompletes as specified in the Handbook of Operating Procedures. Please see your Course Materials Handbook for further information on assignments, grading criteria and course schedule. All other University policies will be followed.

## ATTENDANCE AND PARTICIPATION

In order for this course to be a successful learning experience for you, active and committed participation on your part is crucial; therefore, as specified in the Information Bulletin, **students are expected to attend class**. All assignments are due according to the Schedule of Assignments in the Course Materials Handbook. Students are expected to take examinations and turn in assignments at the scheduled time. Students who may miss an examination or assignment deadline due to an authorized University activity should make arrangements to complete the assignment in advance, which includes approval from the student's Dean. **Late assignments or examinations will not be accepted**. Please also see the Handbook of Operating Procedures for policies regarding attendance.

The Americans With Disabilities Act and the Rehabilitation Act of 1973: If you have a disability that may have some impact on your work in this class and for which you may require special accommodations, please see a coordinator at Disability Services (MS 2.03.18) so that such accommodations may be arranged. After you receive your accommodation letters, please meet with me to discuss the provisions of those accommodations as soon as possible.

## ASSIGNMENTS

**Examinations:** Students will be assessed on knowledge of course material through examination. A midterm exam will cover material covered the first half of the semester. The final exam will cover primarily material from the second half of the semester but will be semi-comprehensive. The two exams will consist of a variety of types of questions: multiple choice, true-false, and short essay.

**Family Genogram:** Students will generate a map of multigenerational family relationships for their family of origin.

**Family Networking Diagram:** Students will draft a networking diagram of communication occurring within their family of origin.

**Oral History and Transcription:** Students will conduct an interview with a senior member of their family of origin (parent or grandparent) and transcribe the interview for further in-class analysis and research.

**Weekly Journal:** Students will write their reflections on issues of family in a personal journal for weekly submission.

A full description of each of these assignments can be found in the Course Materials Handbook, which is located in WebCT, or through the course website Student Section at [hleblanc.com](http://hleblanc.com)

**Due to the content of this senior-level course, students should be aware that subject matter of a very personal and mature nature may be discussed in the class. However, the course is not intended nor is it designed to serve the purpose of marital or family counseling.**

## DIVISION OF ASSIGNMENTS

|   | <u>GRADING SCALE:</u> |
|---|-----------------------|
| MIDTERM EXAM (100 pts.)                 |                       |
| FINAL EXAM (150 pts.)                   | 90.0 - 100: A         |
| FAMILY GENOGRAM (100 pts.)              | 80.0 - 89.9: B        |
| FAMILY NETWORKING ASSIGNMENT (100 pts.) | 70.0 - 79.9: C        |
|   | 60.0 - 69.9: D        |
|   | BELOW 60.0: F         |
| ORAL HISTORY ASSIGNMENT (100 pts.)      |                       |
| WEEKLY JOURNAL (150 pts.)               |                       |

Grades are earned and will be calculated on a cumulative scale. Grades can be calculated by dividing the raw score of the assignment by the total points possible for the assignment. Grades are calculated using a 700 point scale. For example, if the total number of points that can be achieved on the Weekly Journal is 150, then the journal is worth 21.4% of the final grade. The Midterm Exam is worth 100 points. Therefore, a raw score of 78 on the first exam is 11.1% of the final grade. Extra credit will not be assigned for any student due to poor performance or missed assignment. **Grades are not rounded.** You may use the Grade Monitoring Form located in the Course Materials Handbook to calculate your grade average in the course at any time. Furthermore, you may obtain your current grade for assignments in WebCT for this course.

## GRADING RATIONALE

- A** Exceptionally well-prepared completion of assignment indicating effort, individualized style, and impact expected of effective communication.
- B** Unusually well-prepared completion of assignment indicating original application of course materials and individual imagination distinctly superior to average effort.
- C** Satisfactory completion of assignment indicating effort normally expected of the majority of students (basic preparation, correct procedure, and disciplined technique.)
- D** Unsatisfactory completion of assignment indicating technical irregularity, misperceived objectives or methods, unorganized effort, or failure to follow directions.
- F** Failure to complete assignments during the scheduled time through lack of evident effort.

All students will be expected to follow the instructions as they are presented, meet the grading criteria, and turn in each assignment by the due date in order to earn a "B."

This course is a senior-level communication elective. Language and Communication Theory (COM 3083) is a prerequisite for this course. All course requirements are explicitly written in the Course Materials Handbook.

GRADE MONITORING FORM

Name: \_\_\_\_\_ Banner ID: \_\_\_\_\_

GRADING SCALE:

90.0 - 100: A  
80.0 - 89.9: B  
70.0 - 79.9: C  
60.0 - 69.9: D  
BELOW 60.0: F

EXAMINATIONS:

\* Midterm Exam: Total:\_\_\_\_ Possible: 100  
Final Exam: Total:\_\_\_\_ Possible: 150 Tests Total: \_\_\_\_\_

FAMILY GENOGRAM:

\* Assignment 1: Total:\_\_\_\_ Possible: 100

FAMILY NETWORK DIAGRAM:

\* Assignment 2: Total:\_\_\_\_ Possible: 100

ORAL HISTORY AND TRANSCRIPTION:

Assignment 3: Total:\_\_\_\_ Possible: 100

WEEKLY JOURNAL (10 pts per week for 15 weeks):

Number of weeks: \_\_\_\_ (x15)

Assignment 4: Total:\_\_\_\_ Possible: 150 Assignments Total: \_\_\_\_\_

-----  
\* MIDTERM: Total:\_\_\_\_ Possible: 300 Percent:\_\_\_\_ Grade: \_\_\_\_\_

FINAL GRADE: Total:\_\_\_\_ Possible: 600 Percent:\_\_\_\_ Grade: \_\_\_\_\_

LIST OF IMPORTANT DATES

|              |  |
|--------------|--|
| January 12:  | Classes begin.   |
| January 16:  | Final date for adding the course.                                    |
| January 28:  | Final date for dropping the course without receiving a grade of “W”. |
| January 30:  | Assignment 1 due at 9:00am.  |
| February 20: | Assignment 2 due at 9:00am.  |
| March 1:     | Midterm Exam 1.  |
| March 12:    | Final date for dropping course.                                      |
| March 15-20: | Spring Break.  |
| March 24:    | Weekly Journal for Week 10 due at 9:00am.                            |
| March 29:    | Assignment 3 due at 9:00am.  |
| April 28:    | Last Day of Class. Last Weekly Journal entry due at 9:00am.          |
| May 4:       | Final Exam period: (7:30am - 10:15).                                 |
| May 11:      | Final grades due.  |

Dates for class assignments and exams will not be altered. We will meet during the Final Examination period for this section. Unless otherwise indicated, assignments are due at the beginning of the class period as assigned. The Weekly Journal assignments will be every Friday except as noted above.

SCHEDULE OF ASSIGNMENTS AND ACTIVITIES

Week One: Defining Family.

- Read Chapters 1 and 2.

Week Two: Theoretical Frameworks for Studying Family.

- Read Chapter 3.

Week Three: Creating Family Identity.

- Assignment One: The Family Genogram.

Week Four: Family Roles.

- Read Chapter 4.

Week Five: Family Rules.

- Read Chapter 5.

Week Six: Family Conflict.

- Assignment 2: Family Networking Diagram.

Week Seven: Family Violence.

- Study for Midterm Exam.

Week Eight: Intimacy in the Family.

- Midterm Exam. Read Chapter 6

Week Nine: Communicating Inclusion.

- Read Chapter 7.

Week Ten: Stress and the Family.

Week Eleven: Developmental and Interactional Stressors.

- Assignment 3: Oral History and Transcription. Read Chapter 8.

Week Twelve: Society and the Family.

Week Thirteen: Family Policy.

- Read Chapter 9.

Week Fourteen: Family Talk.

- Read Chapter 10.

Week Fifteen: (Re)defining Family.

- Study for Final Exam.

Final Exam Week: Final Exam (May 4 at 7:30 am).

## THE FAMILY GENOGRAM

Objective: To demonstrate the ability to accurately describe the structure of family relationships.

Directions: Students will draw, on a standard-sized posterboard, a genogram of their family based on the genogram symbols (see below). This genogram should be inclusive of all past and present family relationships for a minimum of three generations in reference to the index person. For the purpose of this assignment the index person is the student completing the assignment.

Characteristics of relationships should include: 1) spousal, 2) sibling, 3) parent/child.

Characteristics of individuals should include: 1) sex, 2) date of birth or birth order, 3) date of death, 4) date of divorce, and 5) date of adoption. Note important and/or critical events, changes in the family structure, and dates for critical events or other issues. To keep the complexity of the genogram to a minimum possible, notes may have to be recorded on the back of the posterboard. After completing the genogram, students will write a narrative essay describing what they have learned about the patterns and history of their family as a result of the genogram assignment. The essay should be no less than one page, single-spaced, and no more than two pages. Students are to include the narrative essay in their journal, appropriately titled.

Sample Genograms are available on WebCT.

Evaluation of the assignment will be based on the following criteria:

- I. Completeness of genogram (three full generations minimum) - 20%.
- II. Accuracy in use of symbols - 20%.
- III. Completeness of information related to individuals - 20%.
- IV. Narrative essay - 30%.
- V. Instructions followed - 10%.

Genogram symbols:

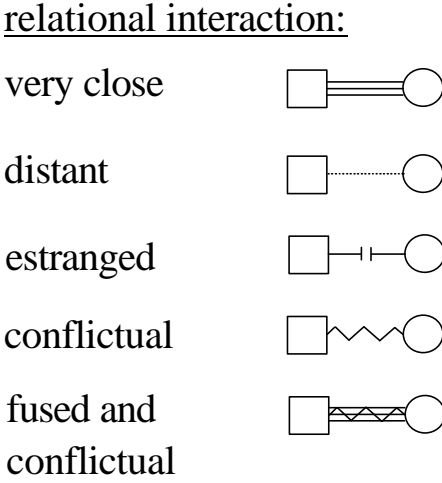
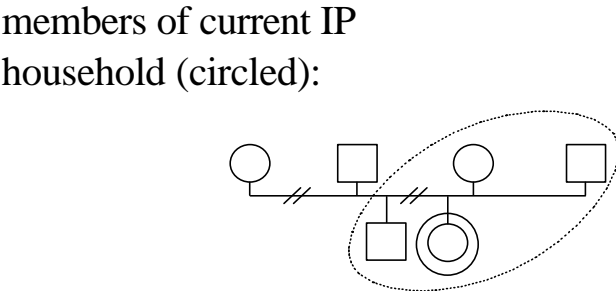
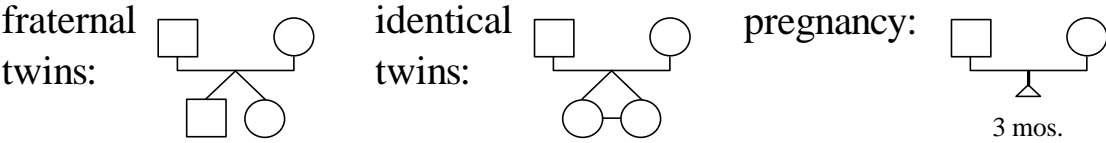
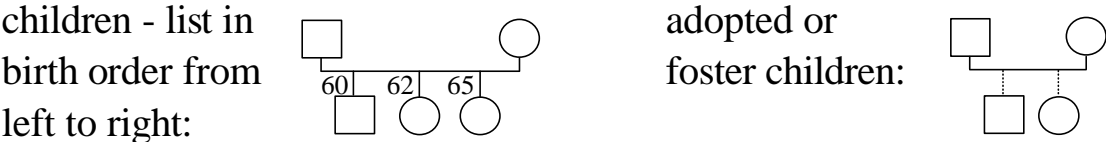
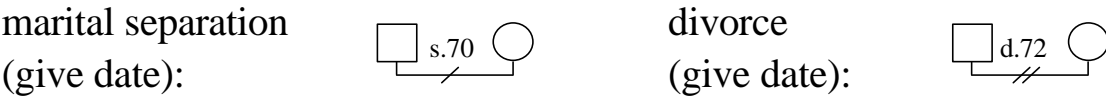
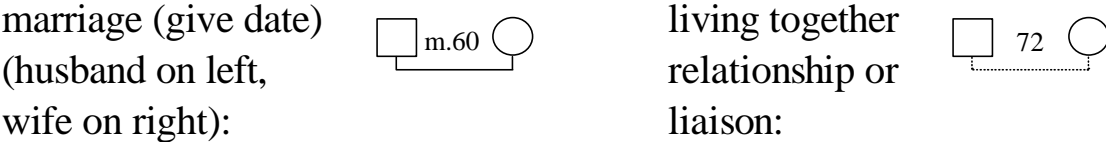

\* Note other relevant information  
 about family interaction.

## FAMILY NETWORK DIAGRAM

Objective: To demonstrate the ability to observe and analyze the direction, flow and characteristics of communication within the family.

Directions: Students will draw, on a standard-sized posterboard, a map of communication networking for their family of origin which demonstrates the direction, flow and characteristics of communication within the family. Students will utilize the family genogram from the previous assignment to list the family members. Secondly, students will utilize the relational interaction symbols from the Genogram Symbols table above to characterize the communication graphically. Thirdly, students will utilize the table of Communication Networks below to demonstrate the direction and flow of communication. Finally, students will describe and analyze in narrative essay form the characteristics of their family communication. The essay should be no less than one page, single-spaced, and no more than two pages. Students are to include the narrative essay in their journal, appropriately titled.

Evaluation of the assignment will be based on the following criteria:

- I. Completeness of family network diagram - 20%.
- II. Accuracy in use of symbols - 20%.
- III. Completeness of information related to individuals - 20%.
- IV. Narrative essay - 30%.
- V. Instructions followed - 10%.

## COMMUNICATION NETWORKS

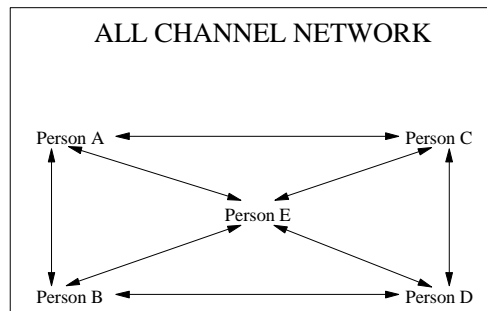
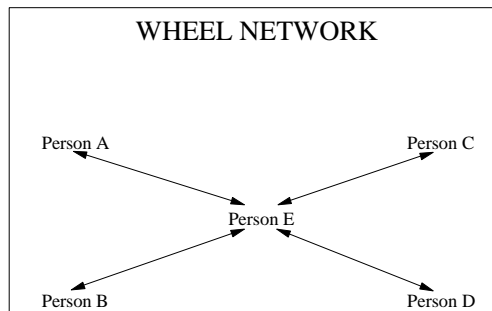
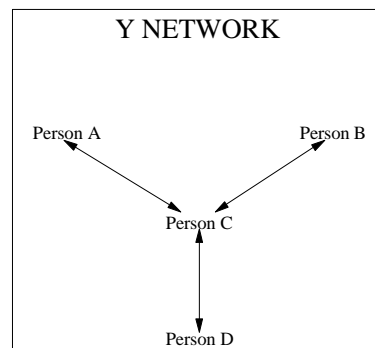
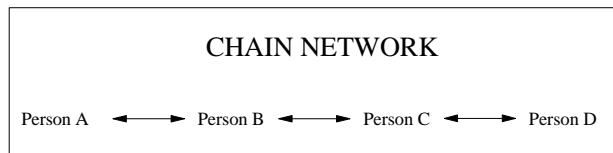

## ORAL HISTORY AND TRANSCRIPTION

Objective: To demonstrate the ability to interview, observe and accurately record family oral history.

Directions: Students will interview a senior member of their extended family of origin such as a parent or grandparent regarding family history according to the interview protocol which will be provided through WebCT. The interview should last no less than 45 minutes and answer all of the questions on the interview protocol in sequence and according to the instructions on interviewing provided in class. The interview should be audiotaped for later verbatim transcription. Students will describe and analyze in narrative essay form the qualities of their family history, for example what was learned about self-identity in the process of hearing oral history. The essay should be no less than one page, single-spaced, and no more than two pages. Students are to include the narrative essay in their journal, appropriately titled.

Students will provide for assessment a written transcript of the interview. The transcripts may be used for later research or in-class analysis according to the requirements of the Institutional Review Board.

Evaluation of the assignment will be based on the following criteria:

- I. Completeness of the transcript - 45%.
- II. Narrative essay - 45%.
- III. Instructions followed - 10%.

## THE WEEKLY JOURNAL

Objective: To demonstrate the ability to reflect on and analyze the issues of importance in family relationships.

Directions: At the beginning of each week, your instructor will give the class a question for reflection. Students will then write their responses to the question in a journal to be turned in for assessment at the end of the week (Friday). Each reflected response should be no less than one page, single-spaced, and no more than two pages. The assignment will be evaluated on thoughtfulness and completeness of response. Each week will be worth 10 points for fifteen weeks of the semester or 150 points.

To complete the assignment, students are requested to purchase a notebook solely for the purpose of keeping a journal. Students are requested to date each entry and include the provocative question at the beginning of each entry.

Evaluation of the assignment will be based on the following criteria:

- I. Thoughtfulness of response - 45% for each entry.
- II. Completeness of response (length) - 45% for each entry.
- III. Instructions followed - 10%

## REFERENCES

The following books represent influential books in the area of Family Communication (originally compiled by Dawn O. Braithwaite, Ph.D., University of Nebraska-Lincoln).

- Aldous, J. (1996). *Family Careers: Rethinking the developmental perspective*. Thousand Oaks, CA: Sage.
- Altman, I., & Ginat, J. (1996). *Polygamous families in contemporary society*. New York: Cambridge University.
- Arliss, L. P. (1993). *Contemporary family communication: Messages and meanings*. New York: St. Martin's.
- Bellah, R. N., Madsen, R., Sullivan, W. M., Swidler, A., & Tipton, S. M. (1985). *Habits of the heart: Individualism and commitment in American life*. Berkeley: University of California.
- Blieszner, R., & Bedford, V. H. (Eds.). (1994). *Aging and the family: Theory and research*. Westport, CT: Praeger.
- Boss, P., Doherty, W., LaRossa, R., Schumm, W., & Steinmetz, S. (Eds.). (1993). *Sourcebook of family theories and methods: A contextual approach*. New York: Plenum.
- Brubaker, T. H. (Ed.). (1990). *Family relationships in later life*. Newbury Park, CA: Sage.
- Brubaker, T. H. (Ed.). (1993). *Family relations: Challenges for the future*. Newbury Park, CA: Sage.
- Cherlin, A. J. (1999). *Public and private families* (2nd ed.). Boston: McGraw-Hill.
- Coontz, S. (Ed.). (1999). *American families: A multicultural reader*. New York: Routledge.
- Demo, D. H., Allen, K. A., & Fine, M. A. (Eds.). (2000). *Handbook of family diversity*. New York: Oxford University.
- Duck, S. W. (Ed.) (1993). *Social context and relationships*. Newbury Park, CA: Sage.
- Fitzpatrick, M. A., & Vangelisti, A. (Eds.). (1995). *Explaining family interactions*. Thousand Oaks, CA: Sage.
- Galvin, K. M., & Brommel, B. J. (2000). *Family communication: Cohesion and change* (5th ed.). New York: Longman.
- Ganong, L. H., & Coleman, M. (1994). *Remarried family relationships*. Thousand Oaks, CA: Sage.
- Ganong, L. H., & Coleman, M. (1999). *Changing families, changing responsibilities*. Mahwah, NJ: Lawrence Erlbaum.
- Imber-Black, E., Roberts, J., & Whiting, R. A. (Eds.). (1988). *Rituals in families and family therapy*. New York: W. W. Norton.
- Kahana, E., Biegel, D. E., & Wykle, M. L. (Eds.). (1994). *Family caregiving across the lifespan*. Thousand Oaks, CA: Sage.
- Klein, D. M., & White, J. M. (1996). *Family theories: An introduction*. Thousand Oaks, CA: Sage.
- McAdoo, H. P. (Ed.). (1997). *Black families*. Newbury Park, CA: Sage.
- Milardo, R. M. (1988). *Families and social networks*. Newbury Park, CA: Sage.
- Noller, P., & Fitzpatrick, M. A. (1993). *Communication in family relationships*. Englewood Cliffs, NJ: Prentice Hall.
- Nussbaum, J. F. (Ed.). (1989). *Life-span communication: Normative processes*. Hillsdale, NJ: Lawrence Erlbaum.

- Nussbaum, J. F., Pecchioni, L. L., Robinson, J. D., & Thompson, T. L. (2000). *Communication and aging* (2nd ed.). Mahwah, NJ: Lawrence Erlbaum.
- Papernow, P. L. (1993). *Becoming a stepfamily: Patterns of development in remarried families*. San Francisco: Jossey-Bass.
- Pearson, J. C. (1997). *Communication in the family: Seeking satisfaction in changing times* (2<sup>nd</sup> ed.). Boston: Addison Wesley Longman.
- Price, S. J., McKenry, P. C., & Murphy, M. J. (Eds.). (2000). *Families across time: A life course perspective*. Los Angeles: Roxbury.
- Sabourin, T. C. (2003). *The contemporary American family: A dialectical perspective on communication and relationships*. Thousand Oaks, CA: Sage.
- Schneider, D. M. (1980). *American kinship: A cultural account* (2nd ed.). Chicago, IL: University of Chicago.
- Socha, T. J., & Diggs, R. H. (Eds.). (1999). *Communication, race, and family: Explorations of communication in Black, White, and Bi-Racial families*. Mahwah, NJ: Lawrence Erlbaum.
- Socha, T. J., & Stamp, G. H. (Eds.). (1995). *Parents, children, and communication: Frontiers of theory and research*. Mahwah, NJ: Lawrence Erlbaum.
- Stacey, J. (1990). *Brave new families*. New York: Basic Books.
- Stafford, L., & Bayer, C. L. (1993). *Interaction between parents and children*. Newbury Park, CA: Sage.
- Sussman, M., Steinmetz, S. K., & Peterson, G. W. (Eds.). (1999). *Handbook of marriage and the family* (2nd ed.). New York: Plenum.
- Turner, L. H., & West, R. (1998). *Perspectives on family communication*. Mountainview, CA: Mayfield.
- Vangelisti, A. L. (Ed.). (2004). *Handbook of family communication*. Mahwah, NJ: Lawrence Erlbaum.
- Visher, E., & Visher, J. S. (1988). *Old loyalties, new ties*. New York: Brunner/Mazel.
- Weston, K. (1991). *Families we choose*. New York: Columbia.
- Yerby, J., Buerkel-Rothfuss, N., & Bochner, A. P. (1998). *Understanding family communication* (2nd ed.). Boston: Allyn and Bacon.

COURSE FEEDBACK FORM

I have enjoyed discussing areas of family communication in the course. However, I would like to know what particular areas you liked or did not like. Please answer the following questions.

1. What do you remember most about family communication as discussed in class?
  
2. Please go back and carefully examine the topics listed on the Schedule of Assignments.
  - a) What topics did you find most intriguing and why?
  
  - b) Do you wish more time were spent in a particular area or less time in another?
  
3. What do you think about the course structure: The form of tests, the assignments, the Weekly Journal, etc.
  
4. What do you think about the online course materials or the Course Materials Handbook?
  
5. What do you think about me as an instructor?
  
6. What suggestions do you have for improvements in the course?
  
7. Are there any other issues relevant to the course that you would like to discuss?

Thank you for your feedback.

H. Paul LeBlanc III, PhD